

CONTENT

1 DEFINITION	3
2 DEVICE PURPOSE	3
3 SECURITY PRINCIPLES.....	4
3.1 SECURITY PRINCIPLES OVERVIEW	4
3.2. SECURITY PRINCIPLES	4
3.2.1 Prior to use.....	4
3.2.2 When in use	5
3.2.3 After use.....	5
3.2.4 Risk analysis	5
3.2.5 Maintenance.....	5
4 PACKING, STORAGE AND HANDLING.....	5
4.1 PACKING.....	5
4.2 STORAGE.....	6
4.3 HANDLING.....	6
5 MAIN SPECIFICATIONS	6
5.1 MECHANICAL DEVICE.....	8
5.2. MATERIAL AND FINISH	8
5.3 DATA ON THE PRODUCT	9
6 JACK OPERATION.....	9
6.1 JACK OPERATION INSTRUCTIONS.....	9
6.2 REST ADJUSTMENT	10
6.3 RATCHET CRANK OPERATION AND THE RATCHET CRANK-LEVER	10
6.4 BEARING SURFACE CHECK-UP /floor, rough ground/	11
6.5 TEST PRIOR TO USE.....	11
7 OPERATION.....	11
7.1 APPLICATION OF THE JACK.....	11
7.2 SAFETY WORK ENVIRONMENT	12
8 CHECK-UP ON THE JACK	12
8.1 INSPECTION	12
8.1.1 Inspections types.....	12
8.1.2 Daily inspection	13
8.1.3 Regular inspection.....	13
8.1.4 Jack occasionally used.....	13
8.1.5 Report on inspection.....	13
8.2 INSPECTION PROCEDURE.....	13
9 TROUBLE-SHOOTING.....	14
10 GREASING.....	15
10.1 GENERALLY	15
10.2 JACK MECHANISM	15
11 MAINTENANCE.....	15
11.1 SECURITY PRINCIPLES	15
11.2 REPLACEMENT OF BRAKE INSERTS AND BRAKE ADJUSTING	16
11.2.1 Brake disassembly (fig. 7)	16
11.2.2 Brake assembly and adjusting (figures 7 and 8)	16
11.3 BEARINGS.....	16
11.4 GENERAL INSTRUCTIONS.....	16
11.5 CHECK UP.....	17
11.6 REPAIR.....	17
11.7 TEST.....	17
12 PUTTING OUT OF OPERATION – LIQUIDATION.....	17
13 LATED DOCUMENTATION.....	17
14 FINAL REQUIREMENTS OF THE PRODUCER TO THE CUSTOMER	17

1 DEFINITION

! HAZARD **Hazard:** it adverts to an imminent hazardous situation, which will inflict death or serious injury, if the operation personnel will not avoid it.

! WARNING **Warning:** it adverts to a possible hazardous situation, which could inflict death or serious injury, if the operation personnel will not avoid it.

! NOTICE **Notice:** it adverts to a possible hazardous situation, which could inflict any minor or slight injury, if the operation personnel will not avoid it. The notice can warn against hazardous practices as well.

Load capacity (Q): is the maximum permitted weight (working load limit) of a load on the jack head, by which the jack is possible to be loaded when handling on conditions specified in this Operation Manual.

Load capacity (Q1): is the maximum permitted weight (working load limit) of a load on the rest, by which the jack is possible to be loaded when handling on conditions specified in this Operation Manual.

2 DEVICE PURPOSE

2.1 The rack jack type 15-00 load capacity 2,5t and 5t, 15-01 load capacity 10t and 16t, Z23 load capacity 20t in any combination of design (-RK, -RKP, -VK) and in design for potentially explosive atmospheres -NEXP (hereinafter referred to as product or NEXP= structurally identical product, differing in surface protection of selected parts, marking plate material and documentation) is designed entirely for manual raising, lowering and pushing of free loads in the workplace. The load weight when raising does not have to exceed specified permitted load capacity.

2.2 The product has been designed in compliance with the requirements stipulated by Directive 2006/42/EC of the European Parliament and the requirements of the harmonized technical standards EN ISO 12100 and EN 1494+A1.

2.3 The product has been designed in compliance with the requirements stipulated by Directive 2014/34/EU of the European Parliament. The product has been designed as **IM2ExhIMb** equipment pursuant to EN ISO 80079-36:2016 and EN ISO 80079-37:2016. It complies with the conditions stipulated for use in mining environments classed as “hazardous atmospheric conditions 2” pursuant to EN 1127-2. 

2.4 The product has been designed in compliance with the requirements stipulated by Directive 2014/34/EU of the European Parliament and of the Council, as amended by the Czech technical regulation – Government Directive No. 116/2016 Coll., as amended. The product has been designed as **I12GExhI1CT6Gb**, **I12DExhI1CT85°CDb** equipment pursuant to EN ISO 80079-36:2016 and EN ISO 80079-37:2016. It complies with the conditions stipulated for use in environments classed as „zone 1 and zone 21“, “zone 2 and zone 22“ pursuant to ~~EN~~ 1127-1. 

Note: Articles 2.3 and 2.4 apply to NEXP product design.

3 SECURITY PRINCIPLES

3.1 SECURITY PRINCIPLES OVERVIEW

A hazard exists when handling loads especially in the event that the jack is not use in the right way or is badly maintained. Whereas as a result an accident or severe injury could happen, it is necessary to observe the special security measures when handling, assembling, maintaining and checking the jack.

! WARNING

ALWAYS ensure the load against drop (i.e. by a stand or jack block), if you are going to work under it.

NEVER burden the jack more than is the load capacity indicated on the jack.

NEVER jack up persons.

ALWAYS warn persons in surroundings before starting work.

ALWAYS read the operation manual and security instructions.

Bear in mind that the operation staff is responsible for faultless technique of raising loads. Hence verify all national directives, regulations and standards whether they contain other information on safety work with your jack.

3.2. SECURITY PRINCIPLES

! WARNING

3.2.1 Prior to use

ALWAYS ensure the jack would be operated by physically fit, qualified and instructed persons older than 18 years, familiarized with the operation manual and trained in security of work and mode of operation.

ALWAYS check up the jack every day before starting work according to section 8.2. (1) „Daily inspection“.

ALWAYS make sure that the lift is adequate for intended work.

ALWAYS respect the jack is on firm foundation.

NEVER jack up loads well set or of unknown weight.

NEVER push with the jack without knowledge of expansion forces.

NEVER use the defective or outworn jack.

NEVER use the jack without visible load capacity marking on the jack.

NEVER use the jack marked with the label „**OUT OF OPERATION**“.

ALWAYS consult the producer or his authorized representative any application of the jack in nonstandard or extreme environment

ALWAYS check that the product is grounded through the ground terminal when working in an explosive atmosphere

ALWAYS wipe off any dust before handling the product in an explosive atmospher

3.2.2 When in use

- ALWAYS** attend to the jack would stay vertically when jacking up.
- ALWAYS** make sure that the foot of the comb bar rests on the ground with the entire contact surface.
- ALWAYS** make sure the load is fitly put on the jack.
- ALWAYS** pay increased attention, if the jack is drawn up to maximum position.
- ALWAYS** work with the jack only with manpower.
- ALWAYS** when jacking up loads with a weight oncoming safe working load of the hoist we recommend the operation would be ensured by two persons owing to magnitude of actuating forces.
- NEVER** use the jack for anchoring of loads.
- NEVER** allow the load would give rise to impacts or vibrations.

3.2.3 After use

- ALWAYS** ensure the jack against incompetent use.

3.2.4 Risk analysis

The possible risks analysis in light of design, operation and environment of the jack appointment is presented in freestanding document „Risk analysis“. It is possible to require the document in service centers.

3.2.5 Maintenance

- ALWAYS** make possible to competent persons to carry out the regular inspection of the jack.
- ALWAYS** ensure slipping parts would be sufficiently greased.

At maintenance only such interventions can be done that will be in accordance with producer's requirements stated in the chapter 11 and 14 of this OM.

IT IS NOT PERMITTED to carry out repairs and maintenance in other manner than specified by the producer. It concerns namely the forbiddance of using of unoriginal spare parts or carrying out changes on the product without the approval of the producer.

4 PACKING, STORAGE AND HANDLING

4.1 PACKING

4.1.1 Jacks are supplied in assembled state in bulk in transport cases.

4.1.2 The following accompanying documentation is a part of the delivery:

- a) Operation Manual
- b) EC Declaration of Conformity
- c) Quality and Completeness Certificates and Guarantee Certificate.
 - c1) Guarantee period is stated in the Guarantee Certificate.
 - c2) The guarantee does not apply to defects caused by infringement of the instructions stated in the Operation Manual and defects arisen by improper using and unskilled action.
 - c3) The guarantee does not apply as well to changes on the product or using of unoriginal spare parts without the approval of the producer.

c4) A claim for defects in the product must be applied according to the relevant provisions of the Commercial Code or the Civil Code, as amended.

d) List of service centers.

4.2 STORAGE

Store jacks in dry and clean stores void of chemical impacts and noxious fumes.

(1) Wipe away all dust, water and impurities from the jack.

(2) Grease the rack of the jack.

(3) Put the jack in a dry place.

(4) In next using follow instructions in the article 8.1.4 „Jack occasionally used“.

4.3 HANDLING

During transportation and handling, observe technical regulations and standards in force for work with heavy loads.

5 MAIN SPECIFICATIONS

The technical parameters of the product in the "NEXP" design for all types, load capacities, designs correspond to the parameters of the standard product design. E.g. product parameters 15-01-NEXP/10t correspond to product parameters 15-01/10t.

Type-design	Load capacity (t)		Actuating force on crank (N)	Main dimensions (mm)							Weight (kg)	
	Q	Q ₁		a	b	b ₁	q	h _{min}	L _{min}	r		Z
15-00	2,5	1,75	380	175	200	200	60	75	735	250	345	15
15-00-RK												16
15-00-VK												16
15-00-VK-RK												17
15-00-RKP												19
15-00-VK-RKP												20
15-00	5	3,5	550	200	235	200	70	85	765	300	360	22
15-00-RK												23
15-00-VK												23
15-00-VK-RK												24
15-00-RKP												24
15-00-VK-RKP												26
15-00	10	7	540	245	290	200	80	90	795	300	320	38
15-01-RK												39
15-01-VK												41
15-01-VK-RK												42
15-01-RKP												40
15-01-VK-RKP												43
15-01	16	11,2	730	280	315	280	77	160	900	400	320	65
Z23	20	14	800	325	330	280	77	150	960	400	300	90
Working temperature range -20° až +50°												

¹⁾ Handle in position "crank"

²⁾ Handle in position "lever"

Main dimensions design - VK

Type-design	Load capacity (t)	P (mm)	R (mm)	O
15-01-VK	2,5	540	90	6
15-01-VK	5	540	90	6
15-01-VK	10	500	100	5

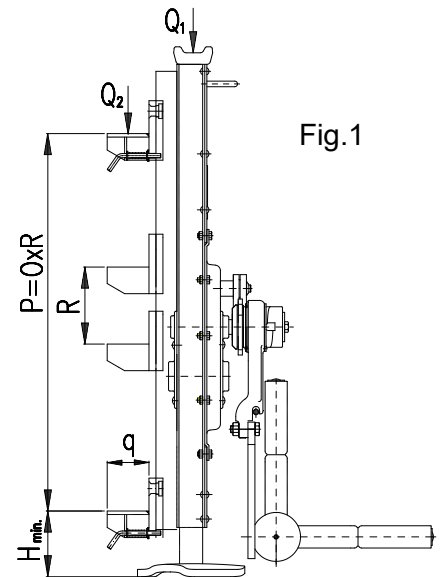

Main dimensions – all type

Fig. 2

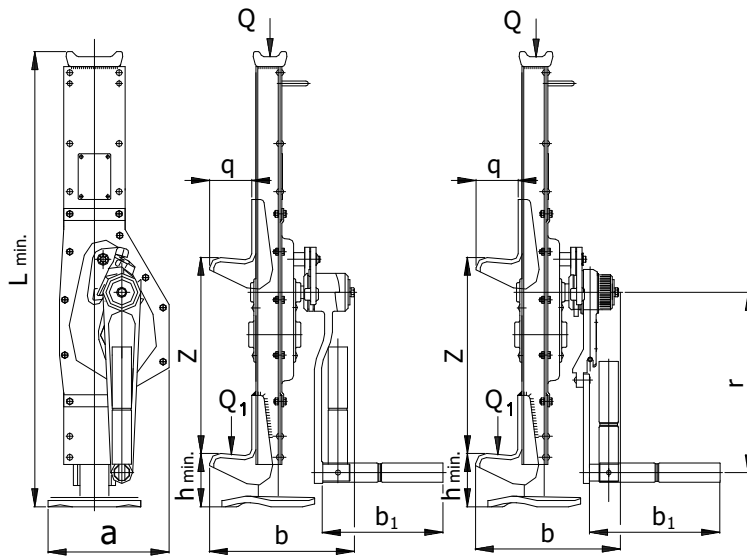

Main dimensions – design - RKP

Fig. 3

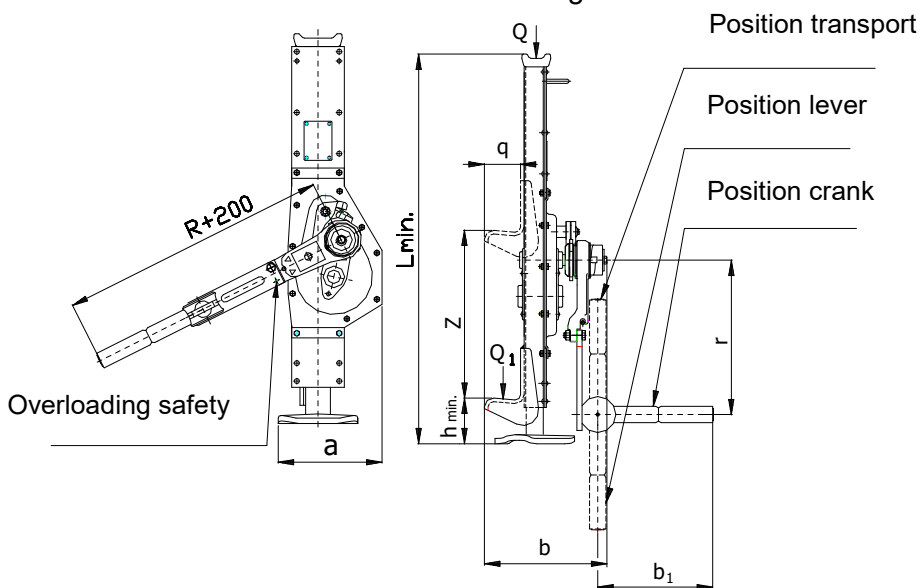

Overloading safety

5.1 MECHANICAL DEVICE

Safety and working life of the jack is guaranteed if it works in accordance with specified classification.

The jack is designed for class 1Bm according to the FEM 9.511 regulation – see table 5.1. (it corresponds to mechanism classification M3 according to the ISO 4301/1).

Average daily operating time is specified in the load diagram.

Tab. 5.1 MECHANICAL CLASSIFICATION

Load diagram (load distribution)	Definition	Load coefficient	Average daily operating time (h)
1 (light)	Jacks usually being subject to the low load and only in special cases to the maximum load.	$k \leq 0,50$	1 - 2
2 (mean)	Jacks usually being subject to the low load, but quite often to the maximum load.	$0,50 < k \leq 0,63$	0,5 - 1
3 (heavy)	Jacks usually being subject to the mean load, but frequently to the maximum load.	$0,63 < k \leq 0,80$	0,25 – 0,5
4 (very heavy)	Jacks usually being subject to the maximum load or load approximating to the maximum.	$0,80 < k \leq 1,00$	0,12 – 0,25

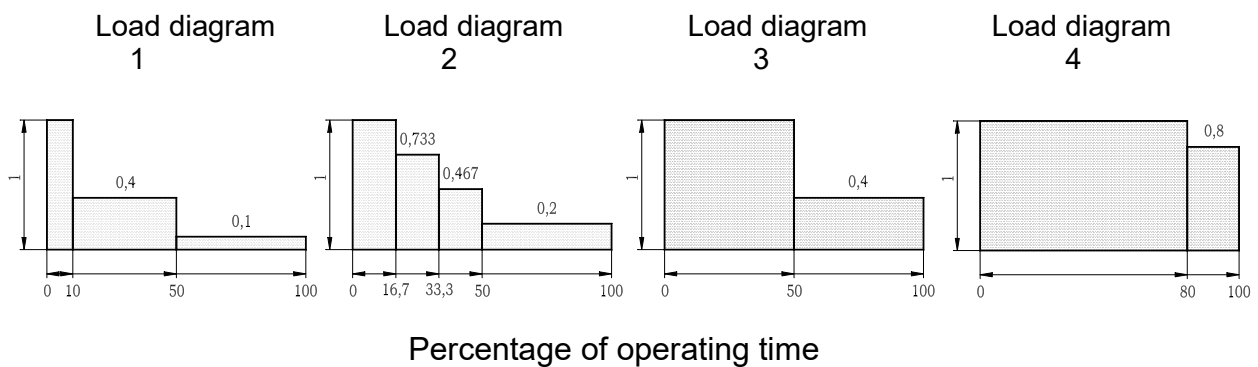

5.2. MATERIAL AND FINISH

5.2.1 All parts of the jack are manufactured from steel and cast iron, the brake liners from hardened woven fabric.

5.2.2. Materials inclinable to creation of an incendiary spark in terms of the annex

5.2.3. Materials with dangerous effects of static electricity within the meaning of the EN 1127-2 article 6.4.7, EN 1127-1 article 6.4.7, EN ISO 80079-36 article 6.7 and are not used in the chain block.

5.2.4 The jack does not exceed the noise value specified in the Annex No.1 article 1.7.4.2 (EP and RE directive No. 2006/42/EC).

Note: Articles 5.2.2 and 5.2.3 3 apply to NEXP product design.

5.3 DATA ON THE PRODUCT

Each product is equipped with the label with specified data as follows:

Standard finish:	NEXP product design:
Mark of the producer	Mark of the producer
Address of the producer	Address of the producer
Product type	Product type
Load capacity	Load capacity
Serial number	Serial number
Production year	Production year
CE marking	CE marking
	Protection type symbol (<i>IM2ExhIMb</i> for group I, <i>I12GExhIICT6Gb</i> and <i>I12DExhIICT85°CDb</i> for group II)

6 JACK OPERATION

! WARNING

ALWAYS before installation check up thoroughly whether the jack is not damaged.

ALWAYS safeguard the jack against drop at pushing or spreading out of loads (i.e. in horizontal direction). A drop can take place when shifting the load and thereby unloading and releasing the jack. Every such handling is necessary to be appreciated individually in terms of safety.

NEVER the load weight or resultant pushing force on the head must not exceed the safe working load of the jack.

The NEXP product must be installed in such a way as to prevent creeping charges. Charging mechanisms stronger than manual friction must be avoided at the installation site.

A NEXP product when used in a mine or other environment where the product could collide with falling, flying... objects (rock, stones...) must be protected to minimize the likelihood of a collision (sufficiently dimensioned cover, ...).

! NOTICE

The jack safe working load on the rest is decreased by 30%.

6.1 JACK OPERATION INSTRUCTIONS

The jack is operated by the crank. Raising or lowering the load can be cut off in any lifting height. A lowering brake and pawl system with forced mesh in the jack crank safeguard the stability of the load position.

! NOTICE

At actuating force greater than 400N (it means when handling with the jack at the safe load limit) the jack must be operated by 2 persons at least.

6.2 REST ADJUSTMENT

(only design - VK).

Position of the adjustable rest can be changed in the range given by a number of mounting positions on the jack bar (see fig.4)

After removal of the breaking piece (2) and shifting of the rest in the direction indicated by an arrow, fastening pin (1) get loose in the jack bar and rest can be put out. Carry out rest fitting-on to other position by opposite procedure.

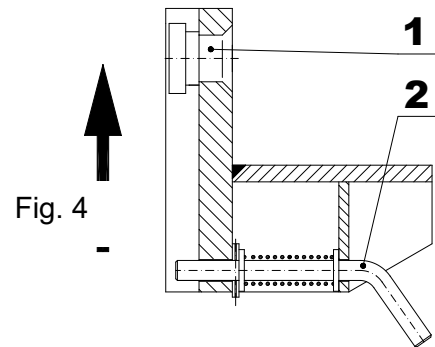

6.3 RATCHET CRANK OPERATION AND THE RATCHET CRANK-LEVER

(only design – RK and – RKP).

6.3.1 Raising or lowering

Before raising hitch up the changeover lever and set on the mark of raising – up-arrow (see fig.5). Carry out the raising by oscillating (eventually rotation) motion of the ratchet crank.

At the beginning of the raising before the loading of the rack jack will take place, hold the knurled nut so that it would not be carried away by the crank at its backwards motion.

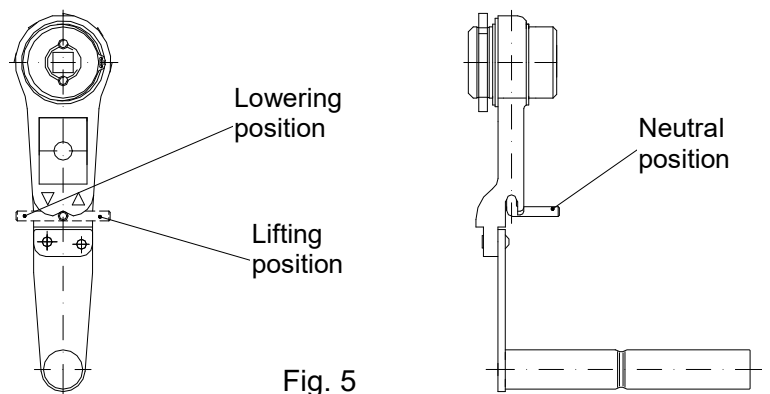

Before lowering the load, shift the changeover lever to the position on the lowering mark – down arrow (see fig.5). Lower down the load by oscillating (eventually rotation) motion of the ratchet crank.

Make sure at each change of the position of the changeover lever, whether the lever gets fitly to the socket in the ratchet crank.

First motion of the ratchet crank after reversing (after shifting of the changeover lever) is slightly blocked. This state arises by an influence of stronger follow-through of the brake namely at manipulation with heavier loads. In this case release the brake by more point-blank motion, thereby you will coincidentally release the ratchet crank.

6.3.2 Ratchet crank-lever

The manipulation with the ratchet crank-lever during the lifting and lowering of loads is performed in the same way as is stated in article 6.3.1 and 6.3.2.

The ratchet crank is changed to an extended lever by folding the crank-lever handle by 90° (into the lever position - see fig.3). We use this position for decreasing the control force during the manipulation with loads that are close to the nominal lifting capacity of the lifter.

The ratchet crank-lever is equipped with a safety shear pin against overloading (see fig.3)

If the shear pin is sheared during the manipulation with a load, it is still possible to lower the load even if the shear pin is sheared (after moving the reverse lever to the lowering position).

! WARNING

NEVER extend the lever's arm with a pipe or by any other method. The lever might get damaged

! NOTICE

The ratchet crank and also the ratchet crank-lever is interchangeable with a standard crank of correspondent type of jack. In case of replacement of the standard crank with the RK 300 ratchet crank at jack with load capacity 5t it is necessary before assembling to put on the square shank of the crank pinion the spacing tube – it is a part of delivery of the RK 300 ratchet crank– for safeguarding the correct position of the ratchet crank on the jack.

6.4 BEARING SURFACE CHECK-UP /floor, rough ground/

! NOTICE

ALWAYS make sure that the bearing surface is sufficiently firm to hold tightly supposed loading for all time of handling. The installation must not be carried out on the surface where it is not possible to determine the load-bearing capacity or that is instable.

ALWAYS the operation personnel are responsible for the set-up!

6.5 TEST PRIOR TO USE

! NOTICE

- (1) At first read again the previous articles of this manual and make sure that all steps were correctly done and all parts are safety mounted.
- (2) Visually check the jack and bearing surface whether they are without defects.
- (3) Put to proof the jack function by the motion of the crank without loading.
- (4) Carry out several jacking up and lowering with the suitable load (10% till 50% of the load capacity). At the same time verify, whether the jack will hold firmly the load without slipping when lowering and stopping.

7 OPERATION

7.1 APPLICATION OF THE JACK

7.1.1 The jack is multifunctional equipment destined for manual jacking up, lowering, pushing and spreading of subjects in the workplace determined by the user. It can be used not only in a current environment, but also in environments with explosion risk in the event that there is the symbol of the protection type marked on the label – see articles 2.3, 2.4 and 5.3 of this OM. The lifters type **15-00** (load capacity 2,5 and 5t) have an opening in the foot which simplifies work when pushing apart objects above head height. The lifter's foot can be easily attached in the required position by using a screw for example, without the need to use a helper. (fig. 6)

Application in horizontal position

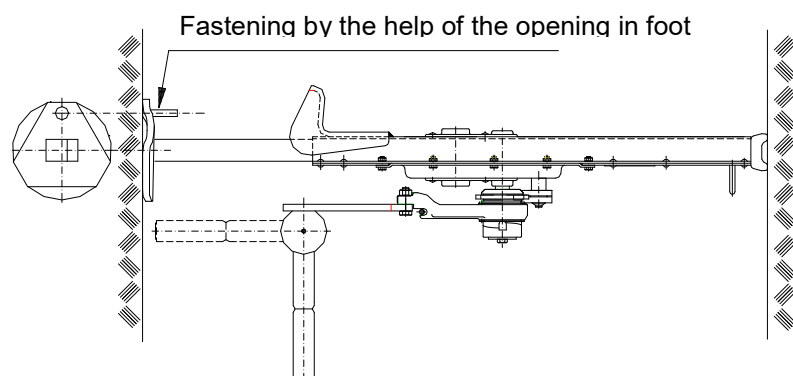

Fig. 6

7.1.2 By reason that the work with heavy loads can constitute unexpected hazard it is necessary to follow all „Security principles“ according to the chapter 3 of this OM.

7.2 SAFETY WORK ENVIRONMENT

! Warning

- (1) The operating personnel must be demonstrably acquainted with this Operation Manual; they must adhere to valid security and hygienic regulations and must be qualified for operation of this equipment.
- (2) When working with the jack the operation staff must be equipped with gloves and appropriate footwear.
- (3) When operating by more persons always one worker must be determined who is trained in safety at work and is responsible for jack handling.
- (4) Before starting the work, the operation staff must check up whether all work area is safety and whether there is the possibility of eventual escape from the environment of jeopardy.
- (5) With a product load capacity of 2,5t and 5t, the cover with the product casing is not sufficiently dimensioned in terms of "breakthrough", therefore any cover that could cause a collision with gears must be repaired or replaced. If the product collides with a falling, flying (object (rock slide...)) that could sufficiently damage the covers, work must be stopped immediately and the product inspected.

8 CHECK-UP ON THE JACK

8.1 INSPECTION

8.1.1 Inspections types

- (1) Introductory inspection: it precedes first use. The responsible competent person must check up all new or repaired jacks to ensure the qualified fulfillment of requirements of this OM.
- (2) The jack inspections carried out regularly are generally divided to two groups according to inspections intervals. Intervals depend on the state of critical parts of the jack and rate of wear, damage or malfunction. Two main groups are here marked as daily and regular ones. The appropriate intervals are defined as follows:

(a) Daily inspection: visual check up carried out by the operation staff determined by the user that is made at the beginning of each use.

(b) Regular inspection: visual check up carried out by the competent person determined by the user.

- 1) Current operation – once a year,
- 2) Heavy operation – every six month,
- 3) Special or occasional operation – according to recommendations of the competent person at first use and according to the order of qualified employees (maintenance workers).

8.1.2 Daily inspection

Check up at parts recommended in the section 8.2(1) „Daily inspection“, whether the jacks are not damaged nor have no defect. Carry out this inspection also during operation in the interval between regular inspections. Qualified employees will determine, whether any defect or damage can constitute a hazard and whether the detailed inspection is necessary.

8.1.3 Regular inspection

Carry out overall inspections of the jack in the form of recommended regular inspections. The recommended regular inspection stated in the section 8.2(2) must be performed under the supervision of the competent persons who will determine, whether the jack is necessary to be taken to parts. These inspections comprise also requirements of the daily inspection.

8.1.4 Jack occasionally used

- (1) Submit the jack not being in operation for a period of one month or longer but less than a year to inspection complying with requirements in the section 8.1.2 before follow-up putting it into operation.
- (2) Submit the jack not being in operation for a period of one year to inspection complying with requirements in the section 8.1.3 before follow-up putting it into operation.

8.1.5 Report on inspection

Keep the record of performed tests, inspections and maintenances of jacks every time. Carry out dating reports on inspections in intervals specified in the section 8.1.1 (2)(b) and keep them in the place specified by the user.

The person responsible for safety and determined by the user must be advised of defects detected by the inspection or recorded during the operation.

8.2 INSPECTION PROCEDURE

(1) Daily inspection (carried out by operating staff or person responsible)

Part	Inspection method	Limit / criteria for putting-out of operation	Remedy
1. Jack function	Visually, aurally	The jack goes hardly, stammers, emits noise etc.	To clean up and grease the jack. If the defect will not be removed, get the jack repaired.
2. Pawls function	Visual inspection when jacking up	Pawls do not snap behind dents of the ratchet.	To clean up, grease, eventually change the spring.
3. Fixative parts	Visual inspection of all screws, nuts, rivets etc.	Faulty or missing parts; Released parts	Replace by new ones; To retighten released parts

(2) Regular inspection (carried out by the competent person)

Part	Inspection method	Limit / criteria for putting-out of operation	Remedy
1. Fixative parts	Visual inspection of all screws, nuts, rivets etc.	Faulty or missing parts; Released parts	Replace by new ones; To retighten released parts
2. All parts	Visual inspection	Outworn or damaged parts; Fouled and ungreased parts	Replace by new ones; To take to parts, clean up, grease and again assemble
3. Label – marking of load capacity on the jack	Visual inspection	Load capacity is not readable	To repair or replace by new one
4. Brake	Jack up and lower the load with weight equal approximately to the load capacity of the jack	When interrupting jacking up the brake must hold firmly the load in each position during raising and lowering	If it will not be so, ask for repair and adjusting of the brake

9 TROUBLE-SHOOTING

Situation	Cause of trouble	Remedy
1. Jack does not hold firmly the load.	Brake slipping.	Brake adjusting or repair according to the chapter „Maintenance“.
2. Jack jacks up heavily or does not raise the load.	(1) Jack is overloaded. (2) Damaged geared transmission.	(1) Lower the load weight to the value of the safe working load. (2) Repair of the jack
3. Jack emits the special noise.	Insufficiently greased geared transmission.	Carry out the lubrication of the geared transmissions by grease.
4. Characteristic sound is not heard when snapping the pawls to dents of ratchet.	Malfunction of pawls. Rust, impurities, broken spring.	Clean up, replace the spring.

10 GREASING

10.1 GENERALLY

Before application of the grease remove old grease, clean up components with grease solvent and apply new grease. Use grease specified by the producer.

Lifters of load capacity 2,5, 5 a 10t are equipped with a lubrication plug on the cover of the gear transfer. We recommend regular lubrication of the gear mechanism at least once every 6 months.

Use grease: Universal lithium plastic lubricant, water resistant, usable in a minimum range of working temperatures from -20°C to +50°C. For example A2, LV2EP.

! WARNING

All lubricants (grease, oil) used in the NEXP version must have an ignition temperature higher than 135°C. E.g. LV2EP,

10.2 JACK MECHANISM

Lubricate products with a load capacity of 2,5t, 5t and 10t with a lubrication press via a lubrication plug on the cover. For 16t and 20t products, slide the unloaded product to the maximum position. Lubricate the comb bar and lower the product.

Grease all slipping or moveable surfaces on the crank of the jack.

! NOTICE

Imperfect maintenance and insufficient greasing can cause a serious accident.

ALWAYS grease more often in corrosive environment (salt water, oceanic climate, acids etc.) than in ordinary circumstances.

11 MAINTENANCE

11.1 SECURITY PRINCIPLES

! Warning

Only qualified persons (service organizations), trained in safety and maintenance of the jacks, can carry out maintenance and professional inspections.

ALWAYS use entirely components supplied by the producer.

It is not permitted to carry out repairs and maintenance in other way than specified by the producer. It means namely the forbiddance of using unoriginal spare parts or carrying out of changes on the product without the approval of the producer.

ALWAYS test jack function after carrying out the maintenance.

ALWAYS mark disabled or repaired jack with appropriate inscription (i.e. „**OUT OF OPERATION**“).

NEVER carry out maintenance if there is the load on the jack.

NEVER work with the jack that is under repair!

ALWAYS when repairing the paint, it is necessary to observe the total thickness of the paint layer maximum 0,2 mm (original + new paint, or after cleaning the surface new paint, applies to NEXP product design).

11.2 REPLACEMENT OF BRAKE INSERTS AND BRAKE ADJUSTING

11.2.1 Brake disassembly (fig. 7)

Demount the (crank or crank-lever) from the jack. Unbolt safety screws (6) and consequently the nut (5). Take out the spring (4) and crank arm (7). Take out from the hub (1) the ratchet (3) with brake insert (2A), take off the brake insert (2B), and replace both brake inserts (2A) (2B).

Fig. 7

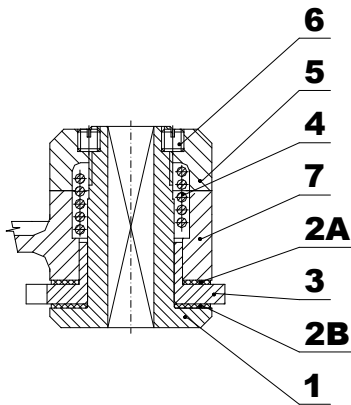
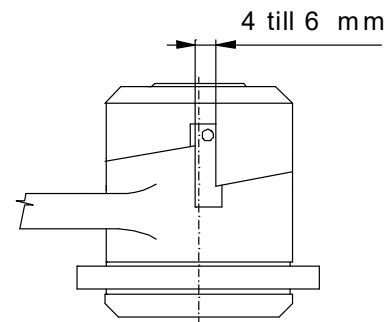

Fig. 8



11.2.2 Brake assembly and adjusting (figures 7 and 8)

Proceed in the opposite way when assembling. Slip over the hub (1) the friction insert (2B); ratchet (3) and second friction insert (2A). Set it in the crank arm (7), slide on the spring (4) and screw on the nut (5). Tighten the nut so that the clearance in the dent is from 4 to 6 mm (see fig. 8) and screw down the screws (6).

11.3 BEARINGS

Cast iron plain bearings are used in the product. The theoretical service life of bearings is several times higher than the theoretical service life of the product. Therefore, they do not need any special maintenance except for cleaning and lubrication during the regular inspection interval, see 8.1. In the event that the bearing is damaged during disassembly, assembly or due to dirt (sand, rock, dust ...) entering the working space of the bearing, the bearing must be replaced immediately.

11.4 GENERAL INSTRUCTIONS

Following instructions give general important information on disassembly, check up, repair and assembly. If the jack was dismantled from any reason act upon the instructions as follows.

1. Perform maintenance in clean environment.
2. **NEVER** disassemble the jack more than it is necessary to carrying out the needful repair.
3. **NEVER** use excessive power when dismantling parts.
4. **NEVER** use heat (fire) as the mean when dismantling parts, if the parts are destined for next use.
5. Keep the workplace clean and without foreign materials that could get into bearings and other movable parts.
6. If you squeeze the part in vice, use always the appropriate pads for protection of parts surfaces.

11.5 CHECK UP

Check up, whether all disassembled parts are suitable for next use.

1. Check up, whether no parts are worn out and have no chutes or fissures.
2. Check up, whether threaded parts have not the damaged thread.

11.6 REPAIR

Outworn or damaged parts must be replaced.

Remove little burrs and scratches or other minor surface defects and flatten out with fine grinder or abrasive cloth.

11.7 TEST

The load test must be performed at all repaired jacks by qualified person with the load exceeding the load capacity by 10% for verification of function and brake of the jack.

12 PUTTING OUT OF OPERATION – LIQUIDATION

The jack do not contain any noxious agents, its parts are from steel and cast iron.

Hand over the jack after putting out of operation to the firm dealing with liquidation of waste metal.

13 LATED DOCUMENTATION

of Law as amended

13.1 EC declaration of conformity

13.2 The Operation Manual was elaborated in accordance with following technical regulations, technical standards and national regulations:

- Ministerial order No.176/2008 of the Collection of Law as amended (EP and Council directive 2006/42/EC)
- Ministerial order No.116/2016 of the Collection of Law as amended (EP and Council directive 2014/34/EU)
- EN ISO 12100
- EN 1494+A1
- EN 1127 - 2
- EN 1127 - 1
- EN ISO 80079-36
- EN ISO 80079-37

14 FINAL REQUIREMENTS OF THE PRODUCER TO THE CUSTOMER

Any changes of the product, eventually usage of unoriginal spare parts can be realized only based on the approval of the producer.

When not observing this condition the producer does not guarantee safety of his product. In this case, any producer's guarantees do not apply to the product.